

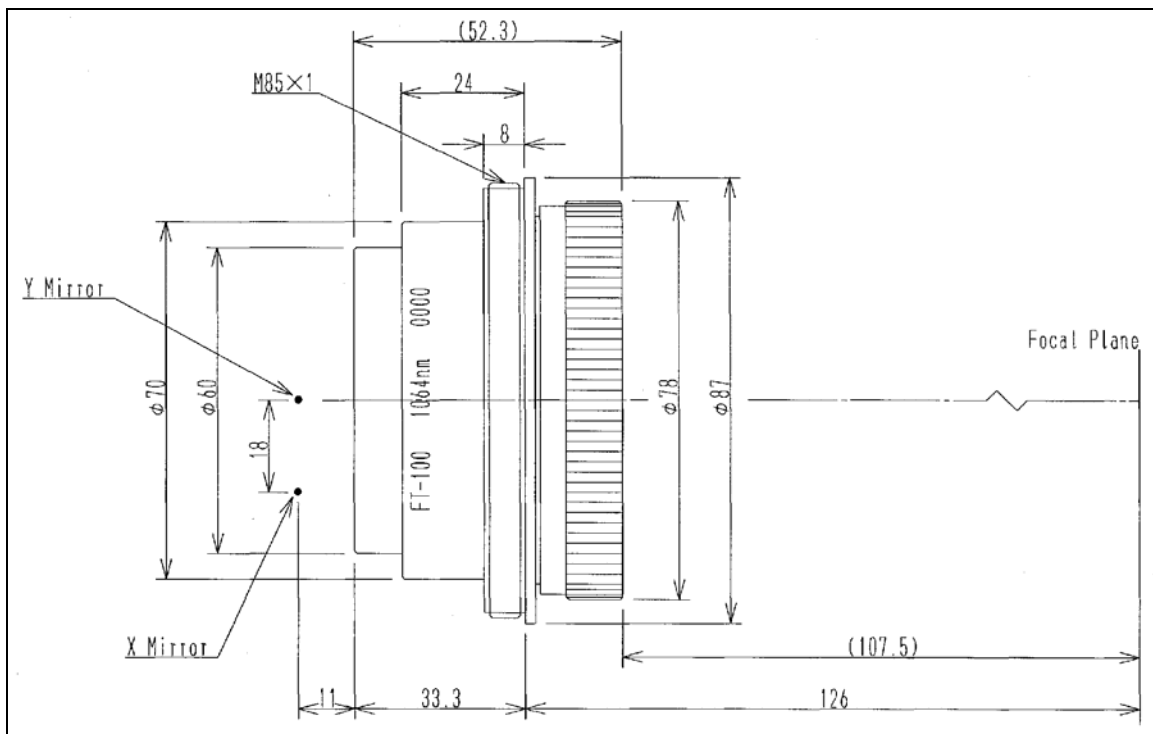

## Model FT-100 – 100mm f-theta Scanning Lens for 1064nm

### GEOMATEC Scan Optics

Designed for High Performance Laser System Applications based on 1064, 532 and 355nm Wavelengths, GEOMATEC Scan Optics offer the laser system integrator superior performance, high quality and excellent uniformity from unit to unit, in some of the smallest packages found in the industry. GEOMATEC's high quality coatings and meticulous manufacturing and quality standards produce robust, highly reliable units you can depend on for your laser system.



Model #	FT-100
Wavelength:	1064nm
Focal Length:	101.3mm
Scanning Area:	80mm $\varnothing$
Entrance Pupil:	12mm $\varnothing$
Spot Size:	17 $\mu$ m $\varnothing$
Scan Angle:	+/-22.68°
Mechanical Back:	107.5mm
Transmittance:	$\geq$ 95%

All dimensions in millimeters unless specified otherwise.  
All specifications subject to change without notice.